



Undermount Model Single Bowl NCFU12FB

Specifications

FEATURES:

- 18 (1.2mm) gauge nickel-bearing stainless steel
- 3-1/2" (89mm) drain opening
- Full undercoat
- Suggested cabinet size: 18" (457mm)
- Shipping weight: 6 lbs. (2.7kg)

OPTIONAL ACCESSORIES:

- Mounting Brackets: LKUMB8 (1)

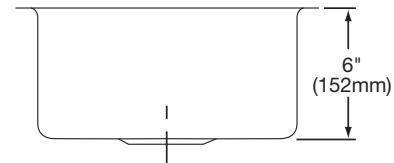
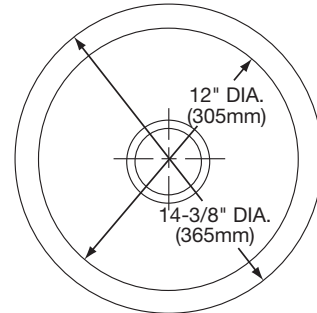

Installation Profile

The template provides this mounting option.

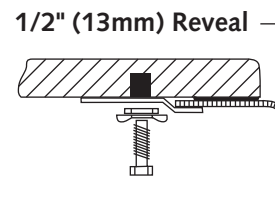

**NOTE: THIS UNDERMOUNT SINK IS DESIGNED TO MOUNT TO
SOLID SURFACE (NON-LAMINATE) COUNTERTOP ONLY.**

In keeping with our policy of continuing product improvement, Revere reserves the right to change product specifications without notice.

This specification describes a Revere product with design, quality and functional benefits to the user. When making a comparison of other producers' offerings, be certain these features are not overlooked.

Revere • 2222 Camden Ct. • Oak Brook, IL 60523 • www.reveresink.com • Tel: (800) 225-8585 • Fax: (630) 645-4447